

SIEMENS

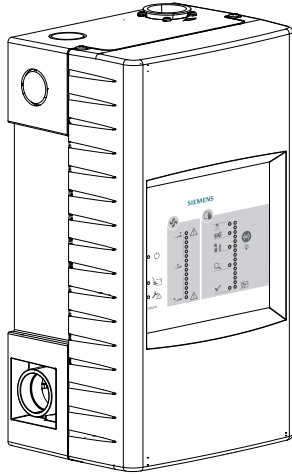

ASD Pipe System

Planning

Mounting

Legal notice

Technical specifications and availability subject to change without notice.

© Siemens Switzerland Ltd, 2011

Transmittal, reproduction, dissemination and/or editing of this document as well as utilization of its contents and communication thereof to others without express authorization are prohibited. Offenders will be held liable for payment of damages. All rights created by patent grant or registration of a utility model or design patent are reserved.

Issued by:

Siemens Switzerland Ltd.

Building Technologies Division

International Headquarters

Gubelstrasse 22

CH-6301 Zug

Tel. +41 41 724-2424

www.siemens.com/buildingtechnologies

Edition: 2015-05-11

Document ID: A6V10334435_e_en_--

Table of contents

1	About this document	5
1.1	Technical terms	7
1.2	Applicable documents	7
1.3	Revision history	8
2	Safety	9
2.1	Safety instructions	9
2.2	Safety regulations for the method of operation	10
2.3	Standards and directives complied with	12
2.4	Release Notes	12
3	System description	13
3.1	Air aspiration variants	16
3.1.1	Direct air aspiration	16
3.1.2	Typical installation below the ceiling	16
3.1.3	Typical installation in false floors or channels	17
3.1.4	Air aspiration via capillary tubes	18
3.1.5	Primary and secondary air intake	19
3.2	Room protection	20
3.3	Air aspiration system	21
3.4	Equipment protection	22
3.5	Water trap in the pipe system	23
3.6	Components of the pipe system	24
3.6.1	Pipes and pipe connections	24
3.6.2	Branches and bends	25
3.6.3	End caps	25
3.6.4	Label for aspirating holes	25
3.6.5	Fastenings	26
3.6.6	Tools	26
3.6.7	Adhesive	26
3.6.8	Water trap	26
3.6.9	Blowing-out unit	27
4	Planning	28
4.1	Planning steps	29
4.2	Site survey	30
4.3	Calculating the details of the pipe system	30
4.4	Designing the pipe system	31
4.5	Planning a pipe system for aspirating smoke detectors	31
4.6	Application of standards for conventional detectors	32
4.7	Network for monitored area	33
4.8	Topology of the pipe system	34
4.9	Pipe system	35

4.10	Limits to planning.....	38
4.11	Determining the sensitivity	39
4.12	Length changes in the pipe system due to a change in temperature	40
4.13	Installing pipes on the ceiling (standard)	41
4.14	Installing pipes in false floors or channels.....	42
4.15	Installing upright stand pipes	43
4.16	Sampling Holes	43
4.17	Ambient conditions	44
4.18	Conditions inside the room	44
4.19	High and open halls and rooms.....	44
4.20	Cavities in ceilings and floors	44
5	Mounting/Installation	45
5.1	Mounting principles.....	45
5.2	Installing the pipe system	46
5.2.1	Trimming the pipes.....	47
5.2.2	Connecting pipes and fittings	48
5.2.3	Installing end caps	49
5.2.4	Fastening the pipe system	49
5.2.5	Drilling the aspirating holes.....	50
5.2.6	Connecting the pipe system to the aspirating smoke detector	52
Index	53

1 About this document

Goal and purpose

This document contains information about planning and installing the pipe system for the following Siemens aspirating smoke detectors:

- FDA241
- FDA221

You will find information about installing, configuring and commissioning the detector in the technical manual for the aspirating smoke detector. See the chapter 'Applicable documents [→ 7]'.
 [→ 7]

Target groups

The information in this document is intended for the following target groups:

Target group	Activity	Qualification
Product Manager	<ul style="list-style-type: none"> ● Is responsible for information passing between the manufacturer and regional company. ● Coordinates the flow of information between the individual groups of people involved in a project. 	<ul style="list-style-type: none"> ● Has obtained suitable specialist training for the function and for the products. ● Has attended the training courses for Product Managers.
Project Manager	<ul style="list-style-type: none"> ● Coordinates the deployment of all persons and resources involved in the project according to schedule. ● Provides the information required to run the project. 	<ul style="list-style-type: none"> ● Has obtained suitable specialist training for the function and for the products. ● Has attended the training courses for Project Managers.
Project engineer	<ul style="list-style-type: none"> ● Sets parameters for product depending on specific national and/or customer requirements. ● Checks operability and approves the product for commissioning at the place of installation. ● Is responsible for trouble-shooting. 	<ul style="list-style-type: none"> ● Has obtained suitable specialist training for the function and for the products. ● Has attended the training courses for Product Engineer.
Installation personnel	<ul style="list-style-type: none"> ● Assembles and installs the product components at the place of installation. ● Carries out a performance check following installation. 	<ul style="list-style-type: none"> ● Has received specialist training in the area of building installation technology or electrical installations.
Commissioning personnel	<ul style="list-style-type: none"> ● Configure the product at the place of installation according to customer-specific requirements. ● Check the product operability and release the product for use by the operator. ● Searches for and corrects malfunctions. 	<ul style="list-style-type: none"> ● Has obtained suitable specialist training for the function and for the products. ● Has attended the training courses for commissioning personnel.
Maintenance personnel	<ul style="list-style-type: none"> ● Carries out all maintenance work. ● Checks that the products are in perfect working order. ● Searches for and corrects malfunctions. 	<ul style="list-style-type: none"> ● Has obtained suitable specialist training for the function and for the products.

Source language and reference document

- The source/original language of this document is German (de).
- The reference version of this document is the international version in English. The international version is not localized.

Document identification

The document ID is structured as follows:

ID code	Examples
ID_ModificationIndex_Language_COUNTRY -- = multilingual or international	A6V10215123_a_de_DE A6V10215123_a_en_-- A6V10315123_a_--_--

Date format

The date format in the document corresponds to the recommendation of international standard ISO 8601 (format YYYY-MM-DD).

Conventions for text marking

Markups

Special markups are shown in this document as follows:

▷	Requirement for a behavior instruction
1. 2.	Behavior instruction with at least two operation sequences
–	Version, option, or detailed information for a behavior instruction
⇒	Intermediate result of a behavior instruction
⇨	End result of a behavior instruction
●	Numbered lists and behavior instructions with an operation sequence
[→ X]	Reference to a page number
'Text'	Quotation, reproduced identically
<Key>	Identification of keys
>	In addition to relation symbols and for identification between steps in a sequence, e.g., 'Menu bar' > 'Help' > 'Help topics'
↑ Text	Identification of a glossary entry

Supplementary information and tips



The 'i' symbol identifies supplementary information and tips for an easier way of working.

1.1 Technical terms

Term	Explanation
ABS	Acrylonitrile-butadiene-styrene
ASD	Aspirating smoke detector
FDnet/C-NET	Addressed detector line
PC	Personal computer
PVC	Polyvinyl chloride
PLC	Programmable logic controller

1.2 Applicable documents

Document ID	Title
A6V10332759	Installation, Operation Manual, Configuration 'ASD Configuration Tool FXS2051'
A6V10344957	Installation Manual for 'FXS2055 ASD Asyst Tool'
A6V10340094	User Manual 'ASD Asyst Tool FXS2055'
A6V10345654	Installation, Mounting Aspirating Smoke Detectors FDA241, FDA221
A6V10334410	Technical manual Aspirating smoke detector FDA241, FDA221

1.3 Revision history

The reference document's version applies to all languages into which the reference document is translated.



The first edition of a language version or a country variant may, for example, be version 'd' instead of 'a' if the reference document is already this version.

The table below shows this document's revision history:

Modification index	Edition date	Brief description
e	2015-05-11	'Components of the pipe system' chapter revised; editorial changes; 'Suppliers' chapter deleted; 'Blowing-out unit' chapter added; 'Technical terms' chapter added; graphics in the 'Installing upright stand pipes' and 'Drilling the aspirating holes' chapters revised
d	2012-11	Information added about planning and system description expanded
c	2012-04	Planning limits adapted
b	2011-12	Revised version
a	2011-11	First edition



The language versions and country variants produced by a local company have the same modification index as the corresponding reference document. They are not however included in the table below.

The table below shows the published language versions and country variants with the corresponding modification index:

Modification index	en_--	de_--	fr_--	it_--	es_--
e	X	X	X	X	X
d	X	X	X	X	X
c	–	X	–	–	–
b	–	X	–	–	–
a	X	X	–	–	–

X = published

– = no publication with this modification index

2 Safety

2.1 Safety instructions

The safety notices must be observed in order to protect people and property.

The safety notices in this document contain the following elements:

- Symbol for danger
- Signal word
- Nature and origin of the danger
- Consequences if the danger occurs
- Measures or prohibitions for danger avoidance

Symbol for danger



This is the symbol for danger. It warns of **risks of injury**.
Follow all measures identified by this symbol to avoid injury or death.

Additional danger symbols

These symbols indicate general dangers, the type of danger or possible consequences, measures and prohibitions, examples of which are shown in the following table:



General danger



Explosive atmosphere



Voltage/electric shock



Laser light



Battery



Heat

Signal word

The signal word classifies the danger as defined in the following table:

Signal word	Danger level
DANGER	DANGER identifies a dangerous situation, which will result directly in death or serious injury if you do not avoid this situation.
WARNING	WARNING identifies a dangerous situation, which may result in death or serious injury if you do not avoid this situation.
CAUTION	CAUTION identifies a dangerous situation, which could result in slight to moderately serious injury if you do not avoid this situation.
<i>NOTICE</i>	<i>NOTICE</i> identifies possible damage to property that may result from non-observance.

How risk of injury is presented

Information about the risk of injury is shown as follows:

	⚠ WARNING
	Nature and origin of the danger Consequences if the danger occurs <ul style="list-style-type: none"> • Measures / prohibitions for danger avoidance

How possible damage to property is presented

Information about possible damage to property is shown as follows:

	NOTICE
	Nature and origin of the danger Consequences if the danger occurs <ul style="list-style-type: none"> • Measures / prohibitions for danger avoidance

2.2 Safety regulations for the method of operation

National standards, regulations and legislation

Siemens products are developed and produced in compliance with the relevant European and international safety standards. Should additional national or local safety standards or legislation concerning the planning, mounting, installation, operation or disposal of the product apply at the place of operation, then these must also be taken into account together with the safety regulations in the product documentation.

Electrical installations

	⚠ WARNING
	Electrical voltage Electric shock <ul style="list-style-type: none"> • Work on electrical installations may only be carried out by qualified electricians or by instructed persons working under the guidance and supervision of a qualified electrician, in accordance with the electrotechnical regulations.

- Wherever possible disconnect products from the power supply when carrying out commissioning, maintenance or repair work on them.
- Lock volt-free areas to prevent them being switched back on again by mistake.
- Label the connection terminals with external external voltage using a 'DANGER External voltage' sign.
- Route mains connections to products separately and fuse them with their own, clearly marked fuse.
- Fit an easily accessible disconnecting device in accordance with IEC 60950-1 outside the installation.
- Produce earthing as stated in local safety regulations.

Mounting, installation, commissioning and maintenance

- If you require tools such as a ladder, these must be safe and must be intended for the work in hand.
- When starting the fire control panel ensure that unstable conditions cannot arise.
- Ensure that all points listed in the 'Testing the product operability' section below are observed.
- You may only set controls to normal function when the product operability has been completely tested and the system has been handed over to the customer.

Testing the product operability

- Prevent the remote transmission from triggering erroneously.
- If testing building installations or activating devices from third-party companies, you must collaborate with the people appointed.
- The activation of fire control installations for test purposes must not cause injury to anyone or damage to the building installations. The following instructions must be observed:
 - Use the correct potential for activation; this is generally the potential of the building installation.
 - Only check controls up to the interface (relay with blocking option).
 - Make sure that only the controls to be tested are activated.
- Inform people before testing the alarm devices and allow for possible panic responses.
- Inform people about any noise or mist which may be produced.
- Before testing the remote transmission, inform the corresponding alarm and fault signal receiving stations.

Modifications to the system design and the products

Modifications to the system and to individual products may lead to faults, malfunctioning and safety risks. Written confirmation must be obtained from Siemens and the corresponding safety bodies for modifications or additions.

Modules and spare parts

- Components and spare parts must comply with the technical specifications defined by Siemens. Only use products specified or recommended by Siemens.
- Only use fuses with the specified fuse characteristics.
- Wrong battery types and improper battery changing lead to a risk of explosion. Only use the same battery type or an equivalent battery type recommended by Siemens.
- Batteries must be disposed of in an environmentally friendly manner. Observe national guidelines and regulations.

Disregard of the safety regulations

Before they are delivered, Siemens products are tested to ensure they function correctly when used properly. Siemens disclaims all liability for damage or injuries caused by the incorrect application of the instructions or the disregard of danger warnings contained in the documentation. This applies in particular to the following damage:

- Personal injuries or damage to property caused by improper use and incorrect application
- Personal injuries or damage to property caused by disregarding safety instructions in the documentation or on the product
- Personal injury or damage to property caused by poor maintenance or lack of maintenance

2.3 Standards and directives complied with

A list of the standards and directives complied with is available from your Siemens contact.

2.4 Release Notes

Limitations to the configuration or use of devices in a fire detection installation with a particular firmware version are possible.

	<p>⚠ WARNING</p>
	<p>Limited or non-existent fire detection Personal injury and damage to property in the event of a fire.</p> <ul style="list-style-type: none"> • Read the 'Release Notes' before you plan and/or configure a fire detection installation. • Read the 'Release Notes' before you carry out a firmware update to a fire detection installation.

	<p>NOTICE</p>
	<p>Incorrect planning and/or configuration Important standards and specifications are not satisfied. Fire detection installation is not accepted for commissioning. Additional expense resulting from necessary new planning and/or configuration.</p> <ul style="list-style-type: none"> • Read the 'Release Notes' before you plan and/or configure a fire detection installation. • Read the 'Release Notes' before you carry out a firmware update to a fire detection installation.

3 System description

Aspirating smoke detectors are used for early detection of smoke-generating fires in rooms and equipment. They are especially suited to applications in which point detectors are pushed to their limits, cannot be used or can only be used with restrictions.

The aspirating smoke detector continually takes air from the monitored room using a connected pipe system with defined aspirating holes. The air is supplied to the detection chamber and is analyzed for smoke particles using the detector installed there. The sensitivity of the detector can be adjusted.

The position and size of the aspirating holes are calculated with the 'FXS2055 ASD Asyst Tool' software. The calculation ensures that the air passes from the aspirating hole to the detector in the time specified and with the required calculated sensitivity.

Examples of application

- Cavities such as false ceilings or false floors
- Rooms with polluted air, in which the pollution has impaired the performance of optical point detectors
- Clean rooms
- Rooms the height of which is greater than that permitted for point detectors
- Rooms with electromagnetic fields which influence the function of point detectors
- Large rooms up to 800 m²
- Separate monitoring of control cabinets and electronics cabinets
- Data centers
- Telecommunication centers
- Mounting lines
- Cable tunnels
- Conveyor belts

Prerequisites for planning the pipe system

In order for a pipe system to be successfully planned, the following requirements must first be met:

- The planner must be familiar with the local fire protection regulations and guidelines.
- A floor plan of the building in which the pipe system is to be installed must be available. The following aspects (in particular) must be visible from the floor plan:
 - Fixtures
 - Installed lighting
 - Electrical installations
 - Gas and water lines
- There must be information available concerning the intended use of the area being monitored, particularly in relation to the fire loads that are present there.
- The planner must know how to use the 'FXS2055 ASD Asyst Tool' software.
- The planner must know how many fire compartments there are in the building concerned and how these compartments are distributed. If compartments are redistributed, the local regulations and guidelines must be observed during this process.
- The planner must be aware of ambient conditions such as temperature and air humidity.
- The planner must be aware of how the air moves in the monitored area (natural air currents and ventilation with air conditioning units).

- To be able to secure the pipe system, the planner must know what material the building is made from, e.g., concrete, timber, bricks.
- The planner must be aware of the ambient conditions (e.g., whether the environment is clean or dusty) or other external influences.
- The preferred use of the aspirating smoke detector must be defined (e.g. whether it is to be used for room protection or equipment protection). See also 'Room protection [→ 20]' and 'Equipment protection [→ 22]'.



Please also watch out for pressure differences >45 Pa! If the aspirating smoke detector is installed outside the monitored area, it may be necessary to route the aspirated air back into the monitored area using a return line.

Connection of external devices

Various external devices can be connected to the aspirating smoke detector:

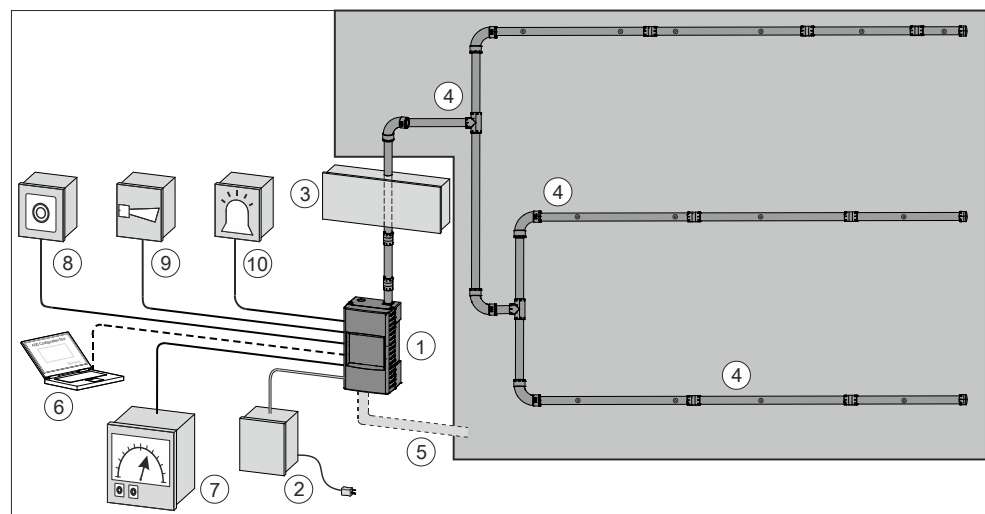

Aspirating smoke detector in standalone operation

- | | |
|------------------------------------|---|
| 1 Aspirating smoke detector | 6 PC with 'FXS2051 ASD Configuration Tool' |
| 2 External power unit with battery | 7 External control/indicator (optional) |
| 3 Blowing-out unit (optional) | 8 External button (optional) |
| 4 Pipe system | 9 External acoustic signal equipment (optional) |
| 5 Return line (optional) | 10 External optical signal equipment (optional) |

Topology of the pipe system

The pipe system can have different topologies.

The choice of topology depends on the following factors:

- Size of the coverage area
 - When using aspirating smoke detector FDA221: up to max. 500 m²
 - When using aspirating smoke detector FDA241: up to max. 800 m²
- Geometry of the coverage area (e.g., shape of room, projections on the wall, false ceilings)

The table below schematically shows different topologies:

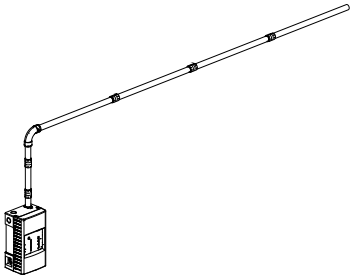
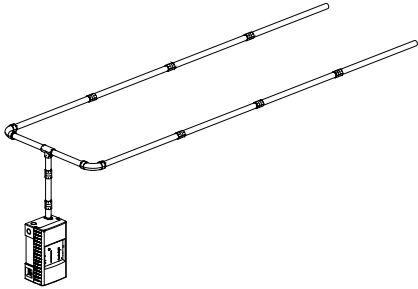
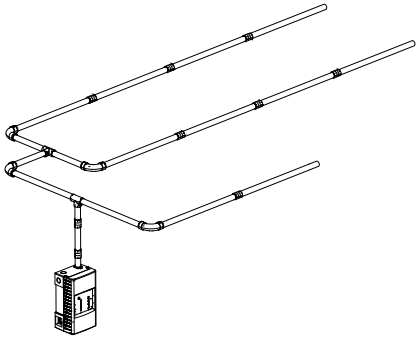
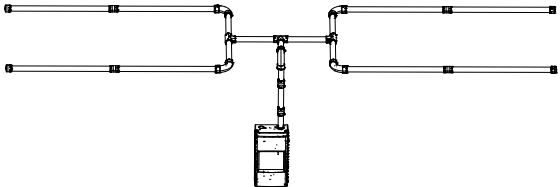
Topology	Graphic display
I-topology	
Symmetrical U-topology	
Asymmetrical U-topology	
Double U-topology	

3.1 Air aspiration variants

- Standard pipe system
 - Takes in air below the ceiling
 - Takes in air from false floors/false ceilings
 - Takes in air from above and from cabinets [→ 22]
- Capillary tubes
 - Takes in air from areas that are not in direct contact with the pipe system [→ 18]
- Primary air intake
 - Takes in air from channels/ducts/air grilles [→ 19]

3.1.1 Direct air aspiration

Aspirating holes, through which the air is aspirated directly into the pipe system, are made in the pipes.

The number, distribution and diameter of the aspirating holes in the pipes must be individually planned for each application.

3.1.2 Typical installation below the ceiling

The air is usually sucked through a pipe system below the ceiling. For this purpose, pipes with aspirating holes are secured below the ceiling.

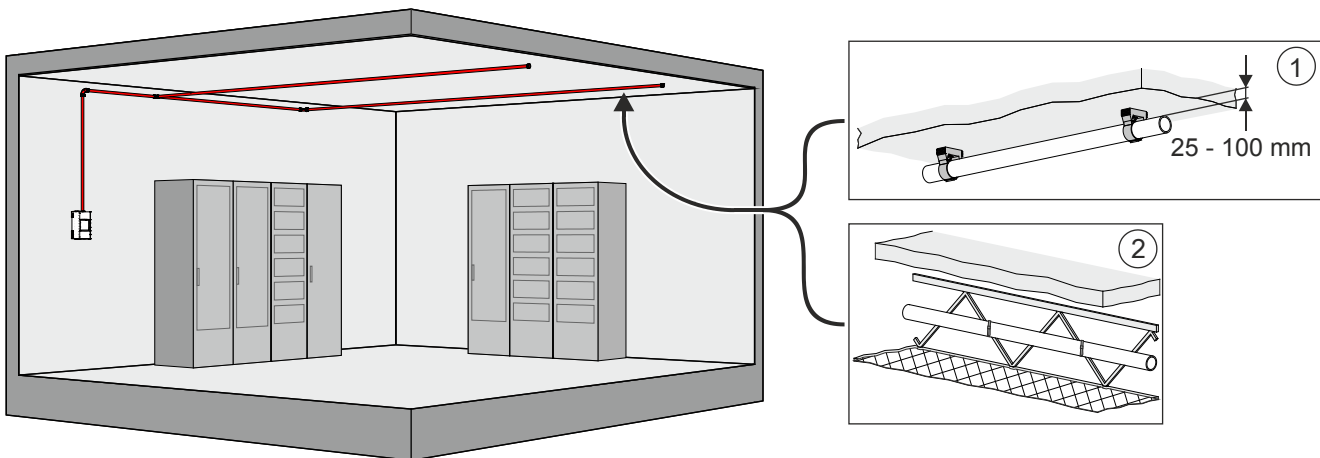

- 1 Secured to ceiling with plastic brackets
- 2 Secured to existing components

See also

- 📄 Installing pipes on the ceiling (standard) [→ 41]

3.1.3 Typical installation in false floors or channels

The air is usually sucked through a pipe system. For this purpose, pipes with aspirating holes are secured in a false floor or channel.

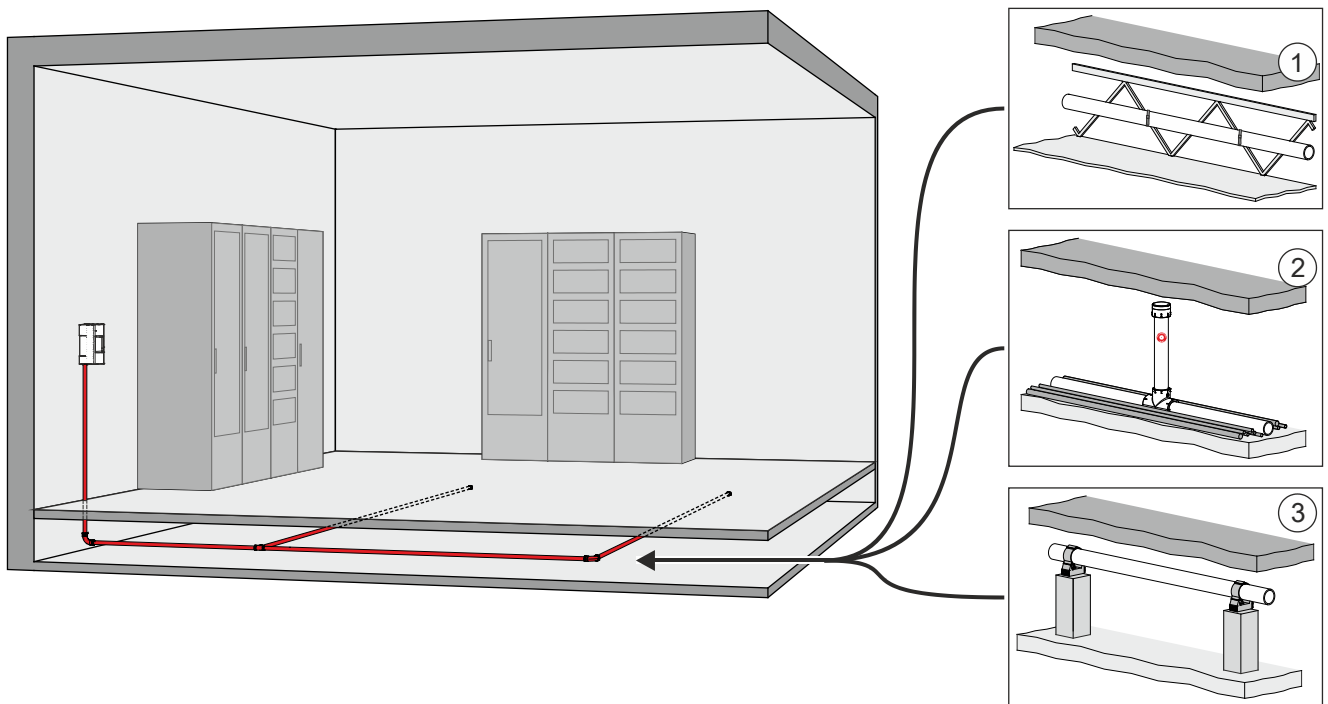

- 1 Secured to existing components
- 2 Upright stand pipes
- 3 Plastic brackets on holders

See also

- 📄 Installing pipes in false floors or channels [→ 42]
- 📄 Installing upright stand pipes [→ 43]

3.1.4 Air aspiration via capillary tubes

The aspirating hole can be connected to the monitored room by a capillary tube. This allows air aspiration in parts of the coverage area that are not in direct contact with the pipe system.

The number, distribution and diameter of the aspirating holes in the pipes must be individually planned for each application.

Examples:

- Aspiration of air directly into control cabinets
- Laying the pipe system in a false ceiling and aspirating air in the room below

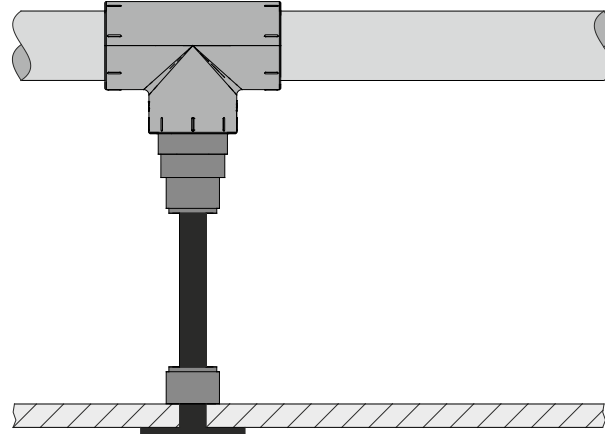

Pipe system with capillary tube

Planning capillary tubes

Always observe the following points when planning capillary tubes:

- Inner diameter of capillary tubes: 5...7 mm
- All the capillary tubes in the pipe system should be of equal length
- Max. length of capillary tubes: 2000 mm
- If the capillary tubes are to be used to aspirate air from individual control cabinets, pay attention to the following:
 - The direction in which the air flows in the control cabinet due to ventilation
 - How the air is likely to flow in the control cabinet in the event of a fire



The pipe system should always be planned using the 'FXS2055 ASD Asyst Tool' software to ensure that the pipe system is as close to optimum as possible.

3.1.5 Primary and secondary air intake

Primary air intake

In the case of rooms with an air conditioning unit or ventilation system (4), the primary air intake (1) is located at the suction point (3) or the suction channel. This enables rapid smoke detection.

Secondary air intake

When the air conditioning unit or ventilation system is switched off, the smoke is detected by the secondary pipe system (2).

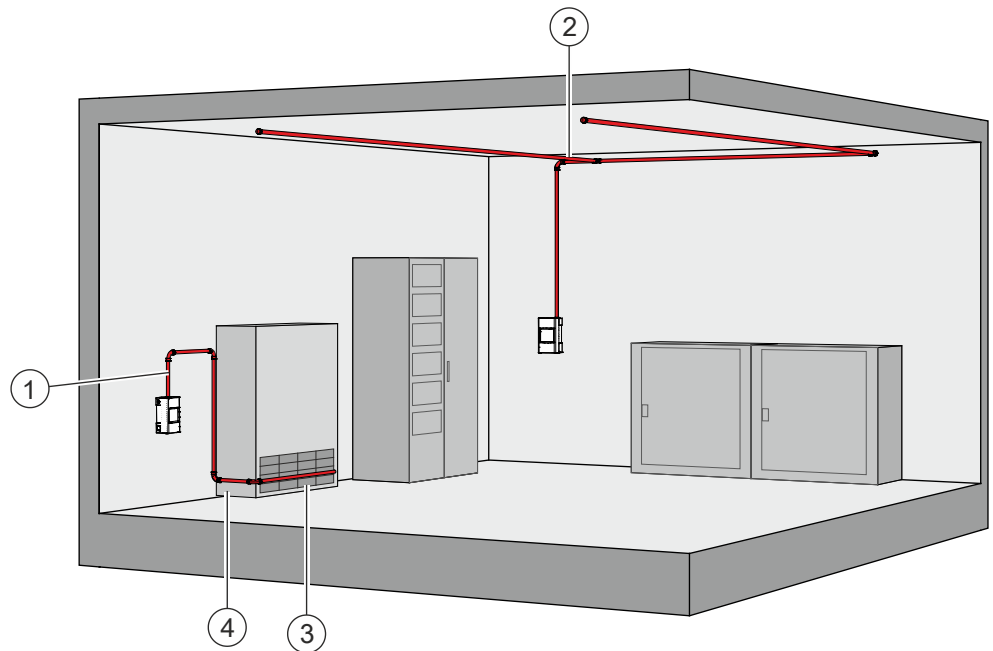

- | | |
|-------------------------|---|
| 1 Primary air intake | 3 Suction point |
| 2 Secondary pipe system | 4 Air conditioning unit or ventilation system |

3.2 Room protection

To monitor rooms, the pipe system is laid in the room in the topology suitable for the application. The aim is to continually monitor a large area.

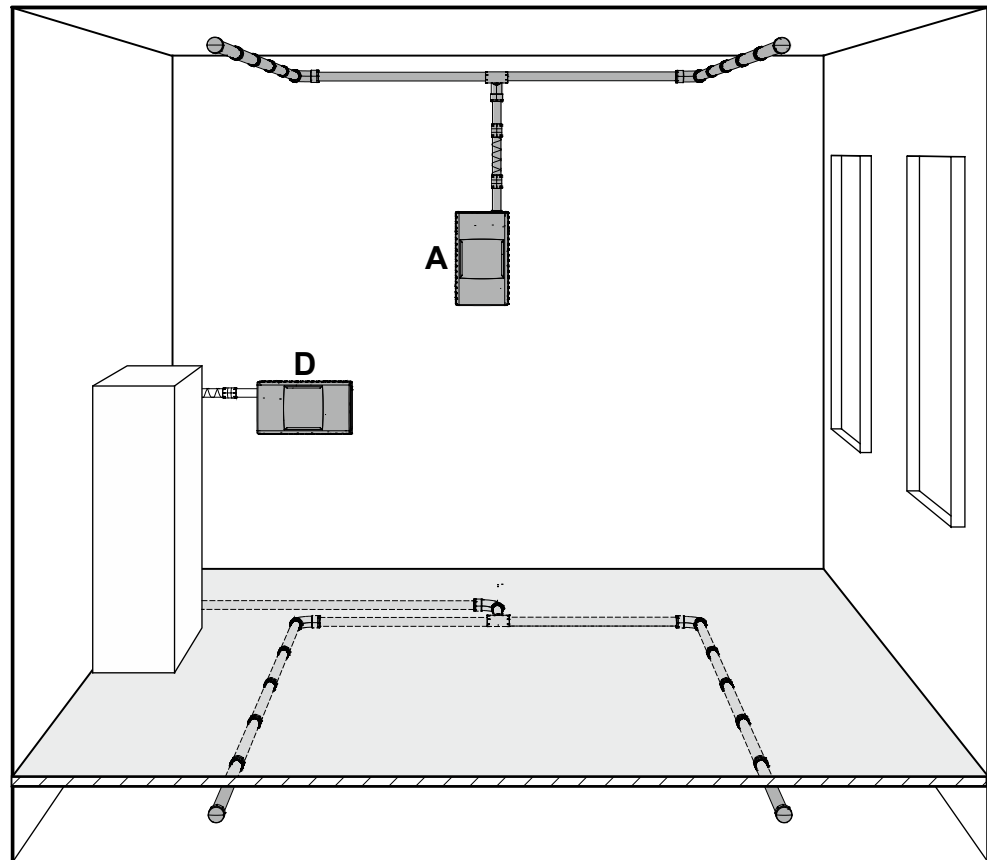

Room protection with two aspirating smoke detectors

A Aspirating smoke detector with pipe system on the ceiling

D Aspirating smoke detector with pipe system in the false floor

3.3 Air aspiration system

Example pipe system for air aspiration

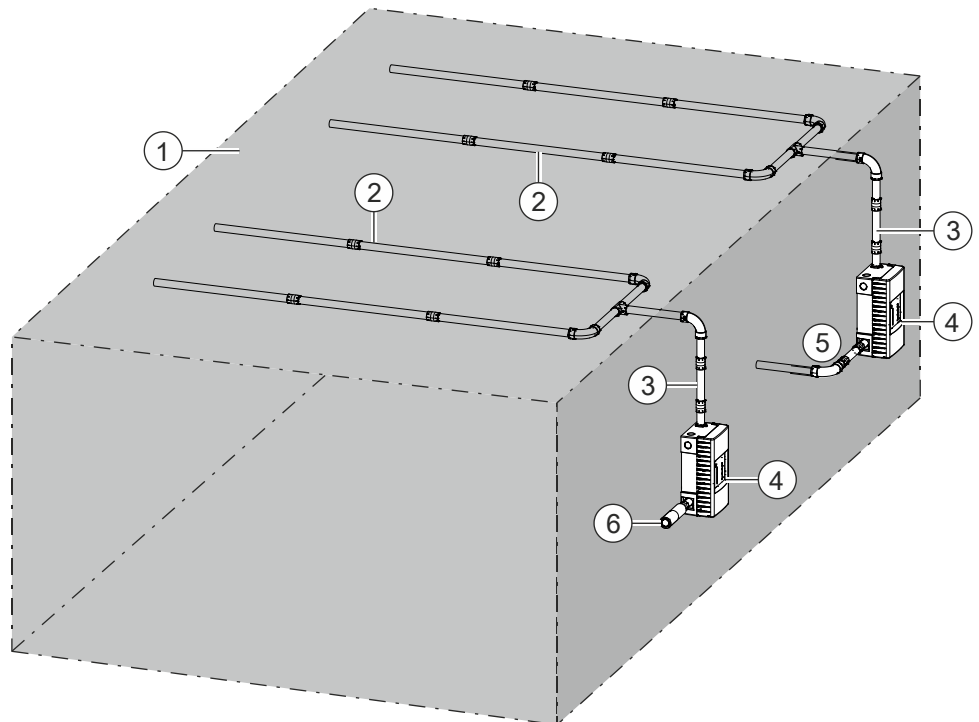

Pipe system

- | | |
|----------------------|---|
| 1 Monitored room | 4 Aspirating smoke detector |
| 2 Pipes and fittings | 5 Outlet line as return line (optional) |
| 3 Hose | 6 Outlet line (optional) |

3.4 Equipment protection

The aim of equipment protection is to directly monitor an area. Examples of directly monitored areas:

- Control cabinets
- Servers
- Switchboard equipment

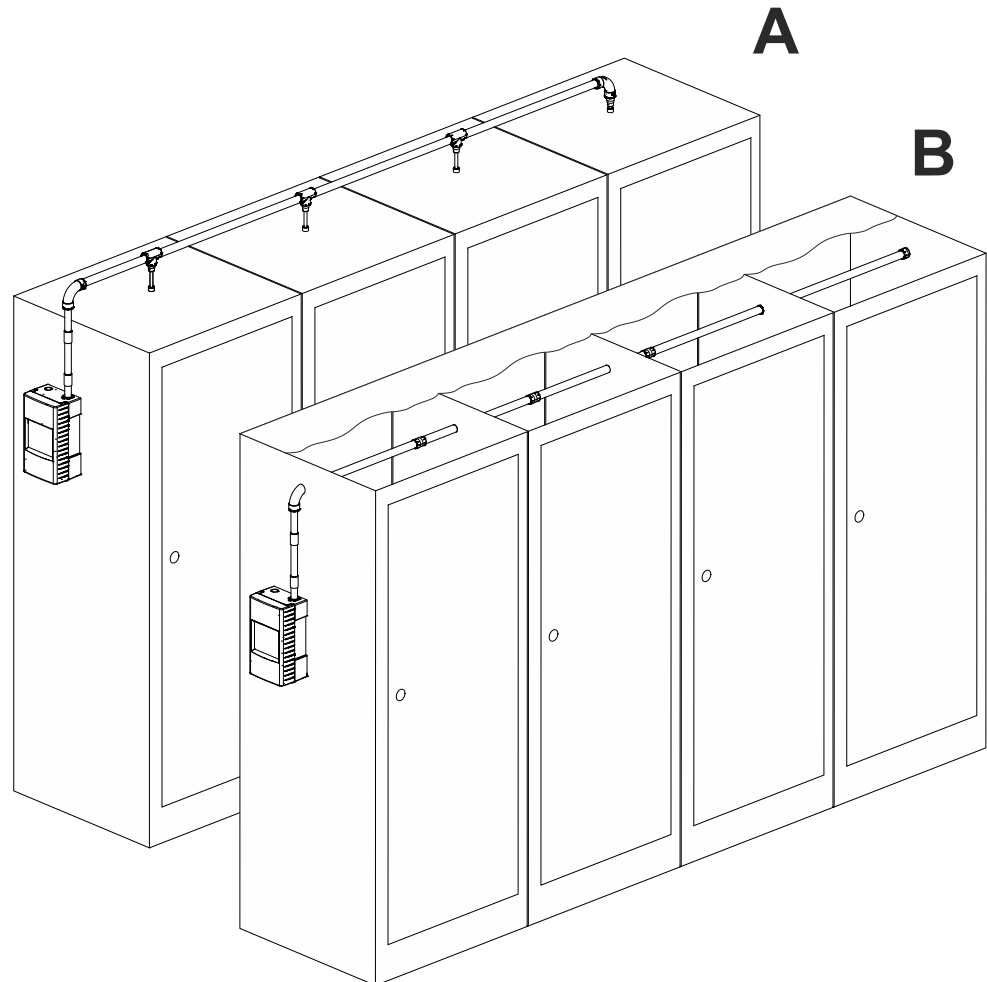

Examples of laying the pipe system on control cabinets (top) and directly through control cabinets (bottom)

A Air aspiration via capillary tubes

B Direct air aspiration

3.5 Water trap in the pipe system

In the case of highly variable ambient conditions where there is a risk of condensation water forming in the pipe system, a water trap must be used. The water trap collects the condensation water. The condensation water must be drained via a drain hole in the water trap.



The condensation water that has been collected must not enter the airflow and must be drained in good time.

Installation site requirements

- It must be easy to read the level of water in the water trap.
- It must be possible to access the water trap when full for the purpose of emptying it.
- The water trap must be installed at a horizontal point within the pipe system that is as low as possible. It must not be possible for water to accumulate at any other point.

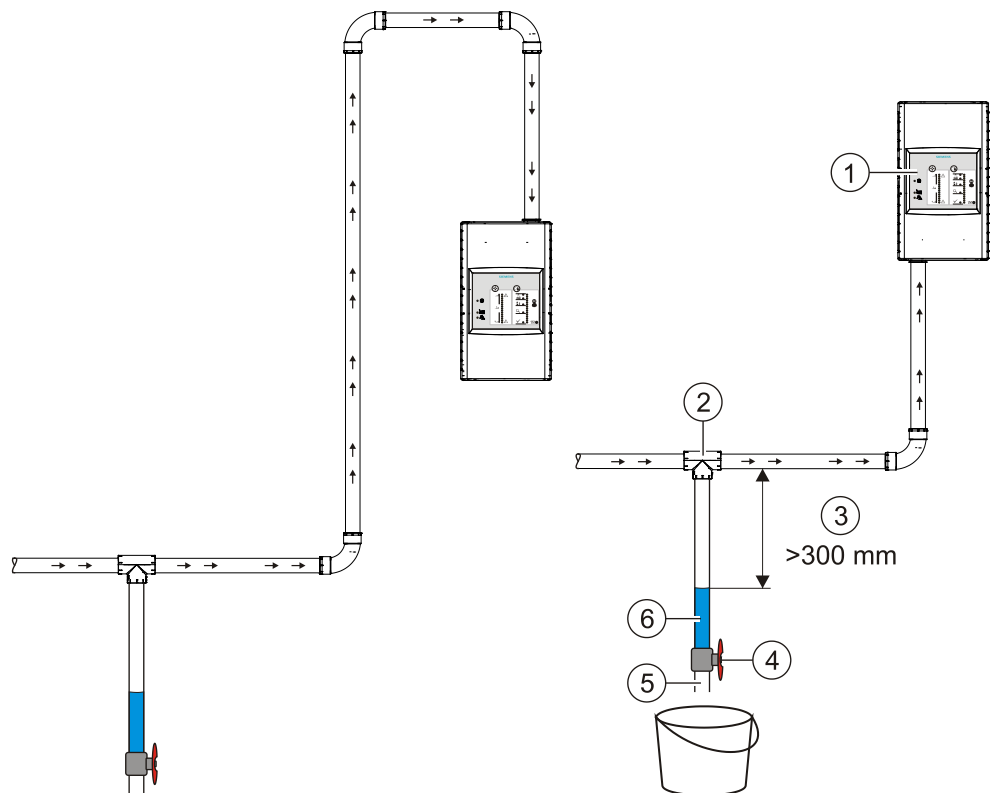

Example of how to arrange a water trap

→ → Airflow

- | | | | |
|---|--|---|---------------------------------------|
| 1 | Aspirating smoke detector with front indicator that is rotated by 180° | 4 | Valve for draining condensation water |
| 2 | T-fitting for connecting the water trap at a low horizontal point within the pipe system | 5 | Outlet opening |
| 3 | Distance between manifold and surface of the water > 300 mm | 6 | Condensation water |

3.6 Components of the pipe system

The following chapters describe different components and tools for setting up a pipe system for aspirating smoke detectors.



Before starting the planning process, check whether there are local or national regulations for selecting the pipe system!



The symbol  is used if there are no graphics for an accessory.

Features of components

It is essential to adhere to the following minimum requirements:

- All components meet the criteria of standard EN 61386-1 class 1131.
- If non-classified pipes are being used, the pipes must satisfy the requirements in EN 54-20, sections 5.7 and 5.8.

3.6.1 Pipes and pipe connections

Pipe

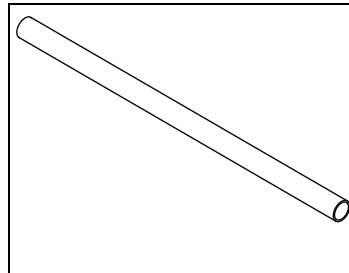

- Piping for air aspiration
- Outer diameter: 25 mm (1 inch)
- Inner diameter: 21 mm
- Pipes can be trimmed to the required length using a pipe cutter
- Pipes can be connected using glued pipe connections
- Material: Typically PVC or ABS depending on the ambient conditions

Pipe connection

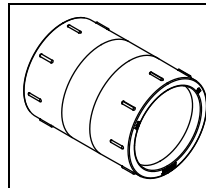

- For connecting two pipes with an outer diameter of 25 mm (1 inch)
- The pipes are glued to the pipe connection
- Material: Typically PVC or ABS depending on the ambient conditions

3.6.2 Branches and bends

90° bend

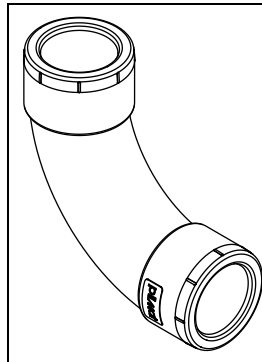

- For changes of direction in the pipe system
- 90° bend angle
- Flange for holding the pipe at both ends
- The pipes are glued to the bend
- Recommendation: Use a bend with the largest possible radius, e.g., 70 mm
- Material: Typically PVC or ABS depending on the ambient conditions

T-piece

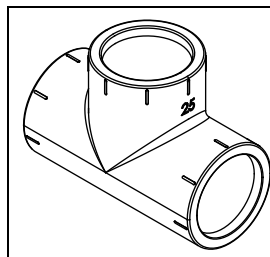

- For branches in the pipe system
- Flange for holding the pipe at all three ends
- The pipes are glued to the T-piece
- Material: Typically PVC or ABS depending on the ambient conditions

3.6.3 End caps

An end cap must be glued to every open end in the pipe system.

End cap

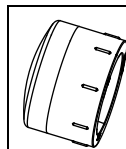

- For fitting on a free pipe end
- The end cap is glued to the pipe
- Material: Typically PVC or ABS depending on the ambient conditions

3.6.4 Label for aspirating holes

Label

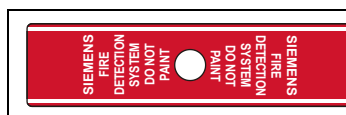

- For identifying aspirating holes on pipes
- Self-adhesive
- Dimensions: 95 x 24 mm, hole diameter 9 mm

3.6.5 Fastenings

Plastic clamp

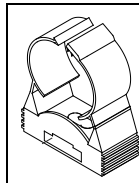

- For attaching the pipes to the wall or ceiling
- The plastic clamps are easy to attach with just one screw or with cable ties
- Pipe can be installed and removed without the need for tools
- Material: Typically PVC or ABS depending on the ambient conditions

3.6.6 Tools

Pipe cutter

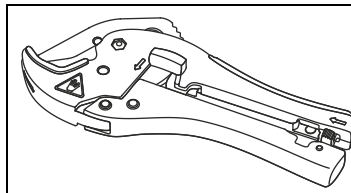

- Pipe cutter for trimming the piping

3.6.7 Adhesive

Adhesive

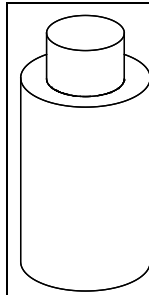

- For gluing fittings to pipes
- Adhesive suitable for connecting ABS or PVC pipes tightly

3.6.8 Water trap

Water trap



- Water trap for installation in the pipe system
- Standard design for collecting condensation water

3.6.9 Blowing-out unit

To ensure that the pipes and the aspirating holes do not get blocked, the pipe system can be cleaned either manually or with an automatic blowing-out unit.

Possible supplier for a blowing-out unit:

Techconnect UG
Rhinstraße 137A
10305 Berlin, Germany
www.techconnect.de

Properties of the blowing-out unit

	<ul style="list-style-type: none">● Automatic blowing out● Activated via either the aspirating smoke detector FDA241 or an internal PLC● Adjustable blowing-out cycles● Outlet pressure: max. 6.5 bar● Operating voltage: DC 24 V
---	---

4 Planning

The pipe system is planned using the 'FXS2055 ASD Asyst Tool' software.

You will find a detailed description of the software in document A6V10340094. See the chapter 'Applicable documents [→ 7]'.



The pipe system should be completely planned before mounting and installing the aspirating smoke detector and the electrical systems and equipment.

During planning, please ensure/note the following:

- You know which area requires protection and are aware of the requirements imposed.
- The fire compartments are defined according to zones. The maximum size for each zone is 1600 m².
- The fire compartments conform to the applicable regulations and standards.
- You are aware of all the customer's requirements and wishes.
- You are aware of the ambient and climatic conditions associated with the area requiring protection.
- You are aware of how the air moves (e.g., air conditioning units, fans).
- You are aware of any usable cavities in the ceiling or floor.
- In the case of high ceilings, be aware that air layers may form.
- Use the 'FXS2055 ASD Asyst Tool' software to plan and design the pipe system so that you can enjoy optimum performance.
- Make a note of all the information.

4.1 Planning steps

For quick and successful planning, proceed as follows:

1. Familiarize yourself with the features of the aspirating smoke detectors. This will help you to select the appropriate aspirating smoke detector and the right topology.
2. Find out about the possible topologies and the various advantages and disadvantages of each one. This will help you to select the correct topology.
3. Get a clear picture of the installation location and the customer's requirements, ideally by visiting the customer's site.
4. Familiarize yourself with the 'FXS2055 ASD Asyst Tool' software so that you can calculate the details of the pipe system.
5. Work through the points listed below. Details are provided in subsequent chapters.
 - Draw the position and number of aspirating holes on a plan.
 - Add a detection network over the aspirating holes.
 - Determine the topology and draw it on the plan.
 - Use the 'FXS2055 ASD Asyst Tool' software to calculate the details of the pipe system.
6. Check that the requirements have been met.
 - ⇒ The necessary sensitivity for the aspirating smoke system has been achieved.
 - ⇒ The planning limits have been observed.
 - ⇒ The environmental requirements at the installation location have been taken into account.
 - ⇒ The customer requirements have been met.

4.2 Site survey

Carry out a site survey to gather essential information for planning the pipe system. This information involves much more than simply measuring the physical size of the fire zone.

Gather information about the following:

- Properties (material and surface) of:
 - Walls
 - Floors
 - Ceilings
 - Furniture
 - Decoration
- Types of room within the fire compartment
- Type of heating
 - Floor heating
 - Overhead heating
 - Radiant heaters
 - Air conditioning unit
- Cavities
 - False floor
 - False ceiling
 - Channels
 - Ducts
- Room geometry in the fire zone
- Boundaries of the fire zone
- Availability of current building plans

4.3 Calculating the details of the pipe system

The final stage of the planning process is to calculate the proposed design using the 'FXS2055 ASD Asyst Tool' software.

Use the data obtained on site as the basis for your calculation. A calculation must be performed with the 'FXS2055 ASD Asyst Tool' software prior to each installation.

4.4 Designing the pipe system

To ensure an effective design, consider the following points:

- Pipe length
- Number of aspirating holes
- Size of end caps
- Number and radius of bends
- Number of pipes
- Length of capillary tubes
- Size of bends and branches
- Air pressure differences
- Division of overall airflow into airflows per pipe
- Equalization of airflows in pipes
- Response time as a measure of how long it takes for the air to be carried from distant aspirating holes to the aspirating smoke detector
- Sampling Hole Sensitivity
- Overall performance of the system with all components
- End caps with openings at the end of the pipes are used to adjust the airflow

4.5 Planning a pipe system for aspirating smoke detectors

- ▷ The planner is familiar with the function of the aspirating smoke detector and the local situation.
 - Distribute the aspirating holes across the room as if they were nodes in a network.
 - Typical mesh sizes are 4 x 4 m, 6 x 6 m, 3 x 3 m.
 - The maximum distance (A) between the wall and the next aspirating hole is 5.1 m.
 - The maximum distance (B) between two aspirating holes is 10 m.
- ⇒ You have created a network of aspirating holes.

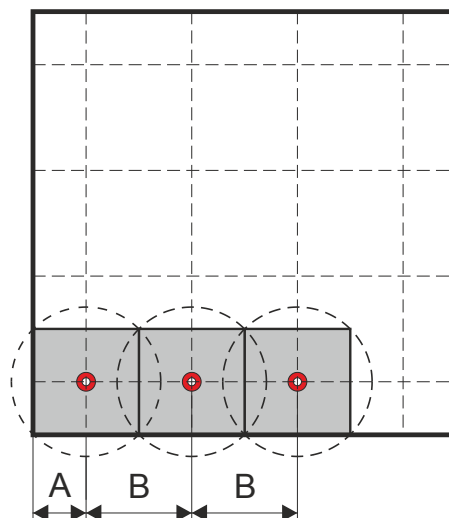

4.6 Application of standards for conventional detectors

Each aspirating hole corresponds to a smoke detector position. Prior to planning and installation, check whether the applicable standards have been sufficiently taken into account. When planning the pipe network, consider how the air moves in the room and the detection area covered by the aspirating holes. Each aspirating hole can monitor an area of between 10 m² and 60 m².

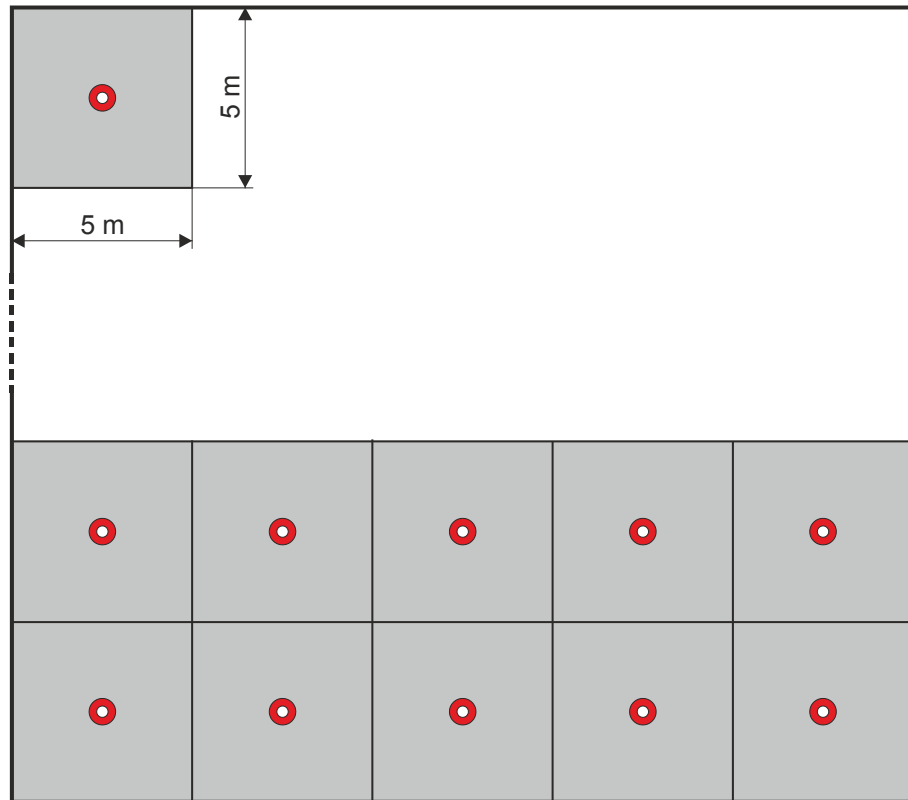

Example detection network with a mesh size of 5 m

4.7 Network for monitored area

Create a network of aspirating holes that covers the area to be monitored.

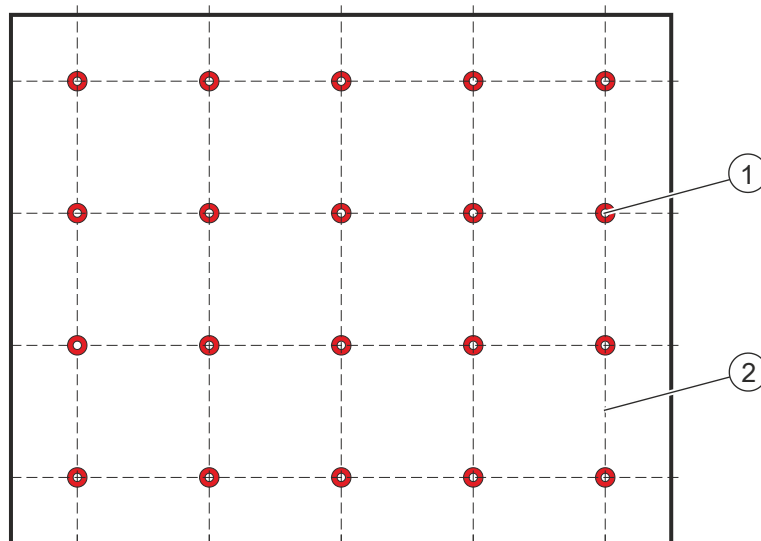

Determining the position of the aspirating holes

1 Aspirating hole

2 Mains

Determine the position and topology of the pipes.

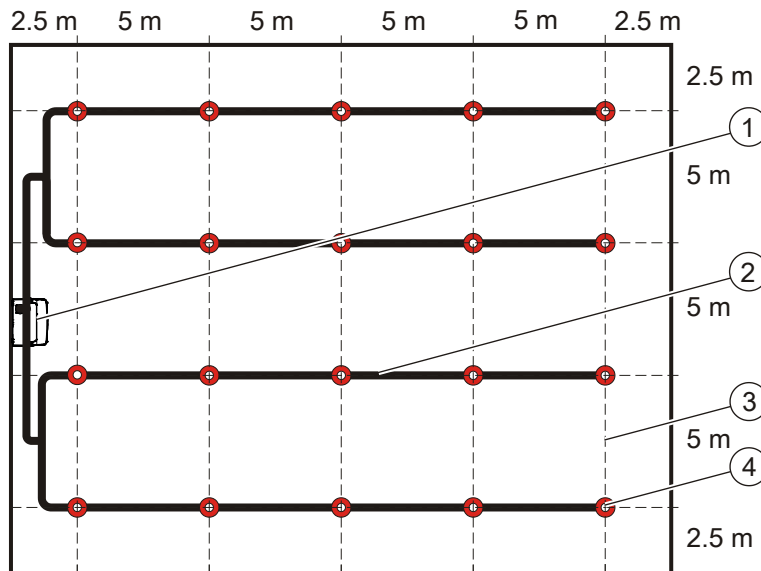

Determining the position of the pipes and the aspirating smoke detector

1 Aspirating smoke detector

3 Network with a mesh size of 5 m

2 Pipe

4 Aspirating hole

4.8 Topology of the pipe system

Select the appropriate topology while taking account of the following:

Feature	Information
Pipe length	A short pipe length equals a short response time.
Number of bends	Fewer bends mean fewer curves and a better laminar flow.
Number of branches	Each branch links airflows.
Number of aspirating holes	The number of aspirating holes can be used to adapt the sensitivity to the room concerned.
System balance	The use of multiple pipes results in improved system balance.
Distribution	The shorter the pipes, the better the distribution of the aspirating holes.
Size of aspirating hole in the end cap	The aspirating hole in the end cap can be used to control the airflow in the pipe.

Examples of different topologies used in the same room

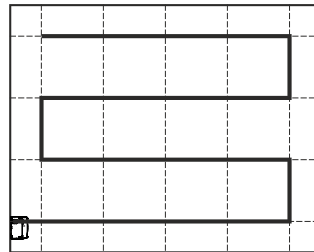

I-topology
with one pipe

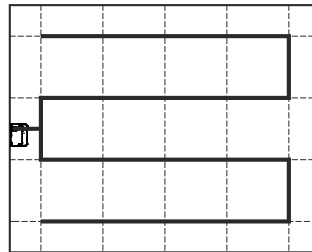

U-topology
with two pipes

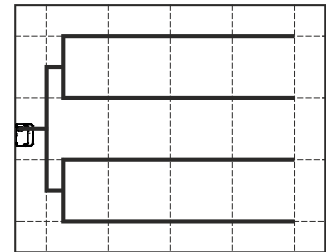

Double U-topology
with four pipes

4.9 Pipe system

It is important that the pipe system ensures reliable detection of a fire.

The example below shows pipe systems with 3 aspirating holes/6 aspirating holes and a symmetrical/asymmetrical arrangement. The diameter of the aspirating holes and the openings in the end caps are calculated using the 'FXS2055 ASD Asyst Tool' software. This ensures a balanced airflow within the pipe system.

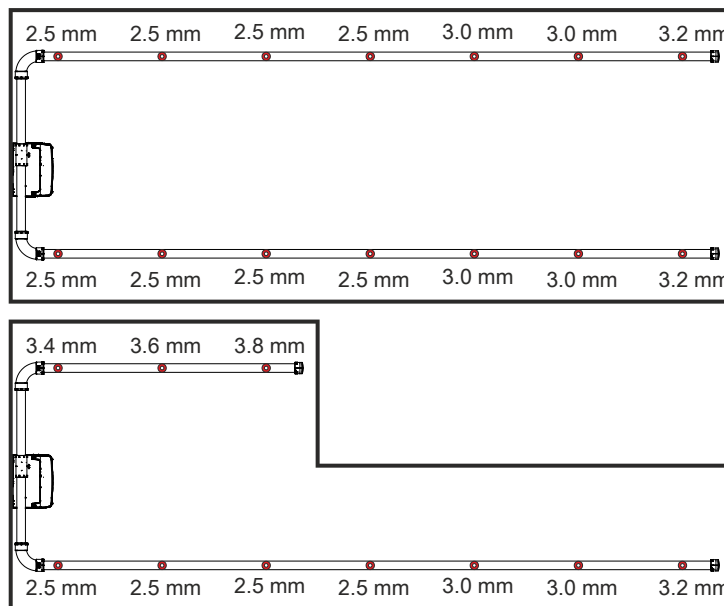

Example of symmetrical and asymmetrical pipe systems with details of aspirating hole diameters

Symmetrical layout

Preferably, you should select a symmetrical layout.

Advantages:

- Same number of aspirating holes per pipe branch
- All pipe branches are the same length (tolerance $\pm 10\%$)
- Same distance between neighboring aspirating holes (tolerance $\pm 10\%$)

Asymmetrical layout

The structural conditions may make it necessary to use an asymmetrical layout.

Conditions:

- As regards the number of aspirating holes in the shortest and the longest pipe branches, there is a minimum ratio of 1:2, which must not be undershot.
- The distance between neighboring aspirating holes should always be the same (tolerance $\pm 20\%$).
- The diameter of each aspirating hole must be determined using the 'FXS2055 ASD Asyst Tool' software and is dependent on the total number of aspirating holes in the pipe branch.

Longer supply lines

If longer supply lines are required between the aspirating smoke detector and the pipe system, the maximum permissible pipe length must not be exceeded as a result.

Topology and length of pipe branches

Short pipe branches result in a quick response time.

- Preferably, you should select short pipe branches. You can achieve this by using a U-topology or double U-topology.
- Remember to adhere to the maximum permissible number of pipe branches and the total length for the pipe system.
- You will find more information in chapter 'Limits to planning [→ 38]'.

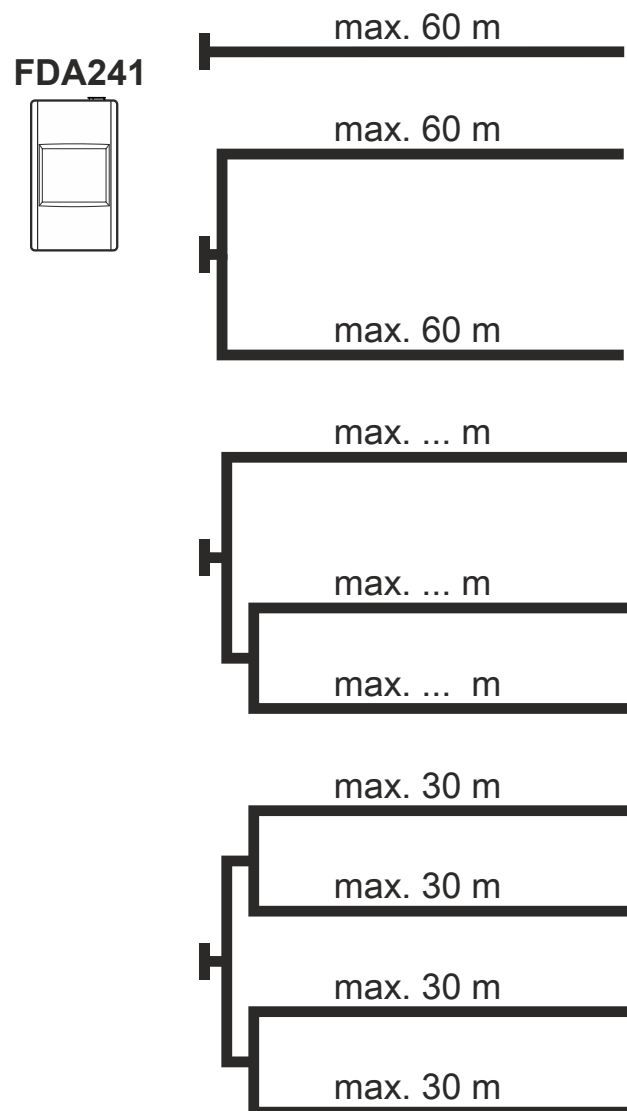
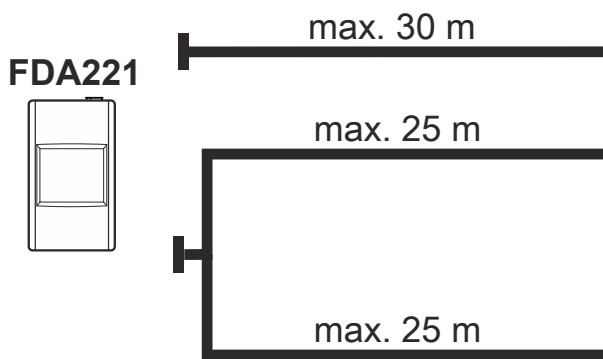

Permissible topologies and pipe lengths

Changes of direction in the pipe system

Whenever the airflow changes direction, losses and deceleration occur. There is an increase in the overall resistance to flow. Therefore, you should use as few branches and bends as possible.



Reduce the number of branches and bends to a minimum.

Check that the permissible piping lengths have been observed.

Use the 'FXS2055 ASD Asyst Tool' software to calculate the details of the pipe system.

Examples of changes in direction with the same length of pipe:



Special cases

If the pipe system cannot be brought into line with requirements for structural reasons, please consult your product specialist.

4.10 Limits to planning



Observe local regulations and specifications for the limits of the detection range of the aspirating holes. The local regulations and specifications take priority over all other information in this document.

The following limits are set for planning the pipe system depending on the aspirating smoke detector used.

Single pipe

Detector	Sensitivity [%/m obs]	Monitored surface	I-topology	
			Length of pipe system	Number of aspirating holes (Class A)
FDA221	0.14...20	≤500 m ²	≤30 m	≤12
FDA241	0.03...20	≤800 m ²	≤60 m	≤16

Branched pipes (symmetrical and asymmetrical U-topology)

Detector	Sensitivity [%/m obs]	Monitored surface	U-topology	
			Length of pipe system	Number of aspirating holes
FDA221	0.14...20	≤500 m ²	≤2x 25 m	≤24
FDA241	0.03...20	≤800 m ²	≤2x 60 m	≤34

Detector	Sensitivity [%/m obs]	Monitored surface	Double U-topology	
			Length of pipe system	Number of aspirating holes
FDA241	0.03...20	≤800 m ²	≤4x 30 m	≤34



Adherence to the planning limits is verified by the 'FXS2055 ASD Asyst Tool' software.

- The maximum number of aspirating holes depends on the sensitivity and whether it is a question of class A, B, or C. You will find these details in the 'FXS2055 ASD Asyst Tool' software (see also the table above).
- In rooms where there is an increased risk (rooms with ventilation systems), the size of the monitored area drops to 270...540 m² with the FDA241 (170...340 m² with the FDA221).

The maximum monitored area depends on the topology selected and the overall maximum pipe length.

4.11 Determining the sensitivity

The sensitivity for the parameter set alarm threshold is set on the aspirating smoke detector. This is the level of sensitivity used to measure the airflow that is made up of air from all the aspirating holes and the end caps.

The sensitivity at an individual aspirating hole is determined according to how much air it contributes to the total airflow. The sensitivity of the individual aspirating hole can be calculated.

Example of how to calculate the sensitivity at an aspirating hole:

The aspirating smoke detector has a sensitivity of 0.1 %/m Obs.

The aspirating hole highlighted by the arrow contributes 5 % of the air that makes up the total airflow.

Therefore, the sensitivity of this aspirating hole can be calculated as follows:

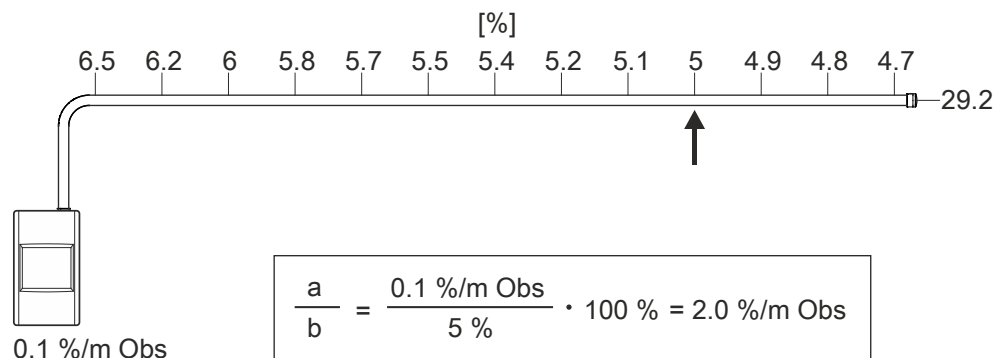

Aspirating holes and how much air they contribute to the total airflow

- a Sensitivity of the aspirating smoke detector (example: 0.1 %/m Obs)
- b Percentage of air contributed to total airflow (example: 5 %)
- Obs Obscuration

Result: The highlighted aspirating hole has a sensitivity of **2 %/m Obs**.

Collective effect

If smoke only comes from one aspirating hole, the aspirating smoke detector detects this according to the calculated sensitivity. (In the example, the sensitivity of the smoke detection system at the highlighted aspirating hole is 2 %/m Obs.) In the event of a fire, smoke usually comes from multiple aspirating holes, which increases the sensitivity of the smoke detection system. If smoke is coming from all the aspirating holes, the sensitivity of the smoke detection system matches the sensitivity of the aspirating smoke detector. (In the example, the smoke detection system has a sensitivity of 0.1 %/m Obs). This is known as the 'collective effect'.

4.12 Length changes in the pipe system due to a change in temperature

A change in temperature causes the lengths of the pipes to change as well.

- With an increase in temperature, the pipes expand and become longer.
- With a decrease in temperature, the pipes get shorter.

Please take account of the change in length during installation. The retainers and fixed points for anchoring the pipes must be designed to allow the pipes to expand unimpeded.

Take account of the following:

- Differences between the installation temperature and the operating temperature
- Variations in operating temperature during use, e.g., differences between summer and winter, day and night, etc.

The change in length is proportional to the change in temperature and can be calculated using the following formula:

$$\Delta L = L \cdot \Delta T \cdot \delta$$

ΔL Linear expansion in [mm]

L Length of the pipe in [m]

ΔT Maximum temperature difference in [°C]

δ Coefficient of linear expansion in [mm/m °C]

$$\delta_{\text{PVC}} = 0.08 \text{ mm/m } ^\circ\text{C}$$

$$\delta_{\text{ABS}} = 0.101 \text{ mm/m } ^\circ\text{C}$$

Example:

A temperature change of 10 °C with an ABS pipe that is 10 m long results in a length change of 10.1 mm.

$$\Delta L = 10 \text{ m} \cdot 10 \text{ } ^\circ\text{C} \cdot 0.101 \text{ mm/m } ^\circ\text{C} = 10.1 \text{ mm}$$

4.13 Installing pipes on the ceiling (standard)

For the pipe system, use the Components of the pipe system [→ 24].

The pipes are secured under the ceiling using plastic brackets.

- The correct distance between the pipe and the ceiling is 25...100 mm.
- The maximum distance (a) between two retaining points is 200 cm. In locations that are subject to strong vibrations and very severe fluctuations in temperature, the maximum distance between two retaining points is 30 cm.
- The mounting components used must allow the pipe to expand freely in the event of temperature changes.
- The mounting components must be placed a considerable distance away from the aspirating holes in the pipe to prevent the aspirating holes from being covered up when the length of the pipe changes due to a change in temperature.

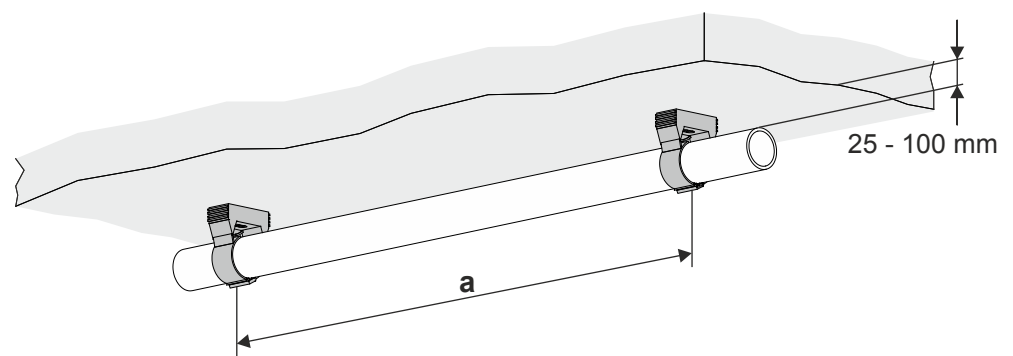

Pipes can also be secured to components using equipment such as cable ties.

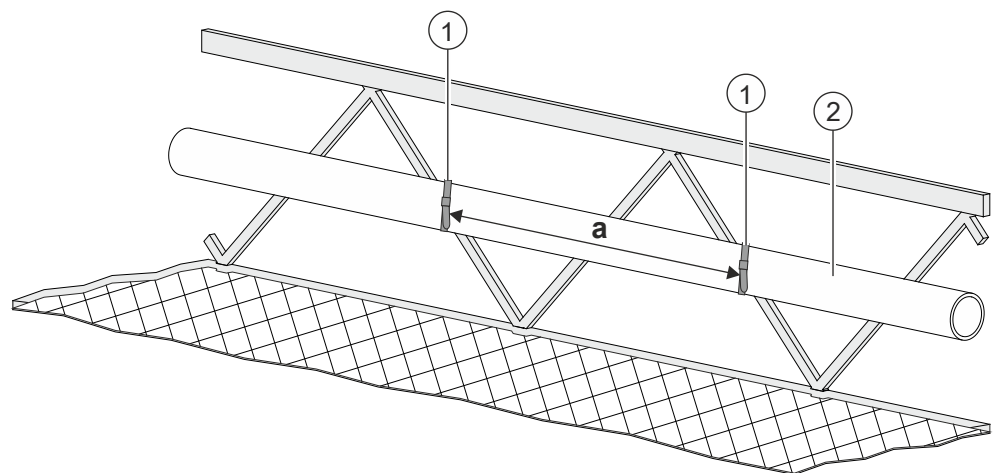

- 1 Cable tie
- 2 Pipe

4.14 Installing pipes in false floors or channels

The pipes can be installed in a false floor or a channel.

- The maximum distance (a) between two retaining points is 200 cm. In locations that are subject to vibrations and severe fluctuations in temperature, the maximum distance between two retaining points is 30 cm.
- The mounting components used must allow the pipe to expand freely in the event of temperature changes.
- The mounting components must be placed a considerable distance away from the aspirating holes in the pipe to prevent the aspirating holes from being covered up when the length of the pipe changes due to a change in temperature.

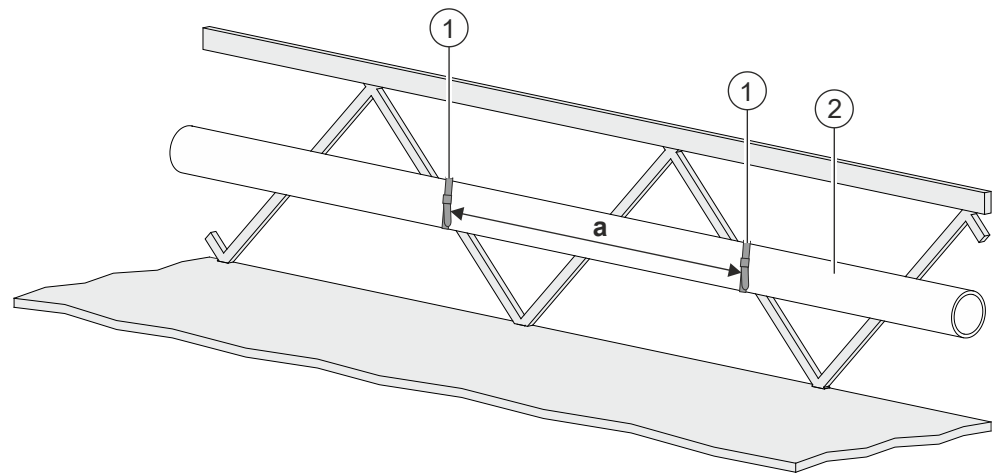

Securing pipes to components

- 1 Cable tie
- 2 Pipe

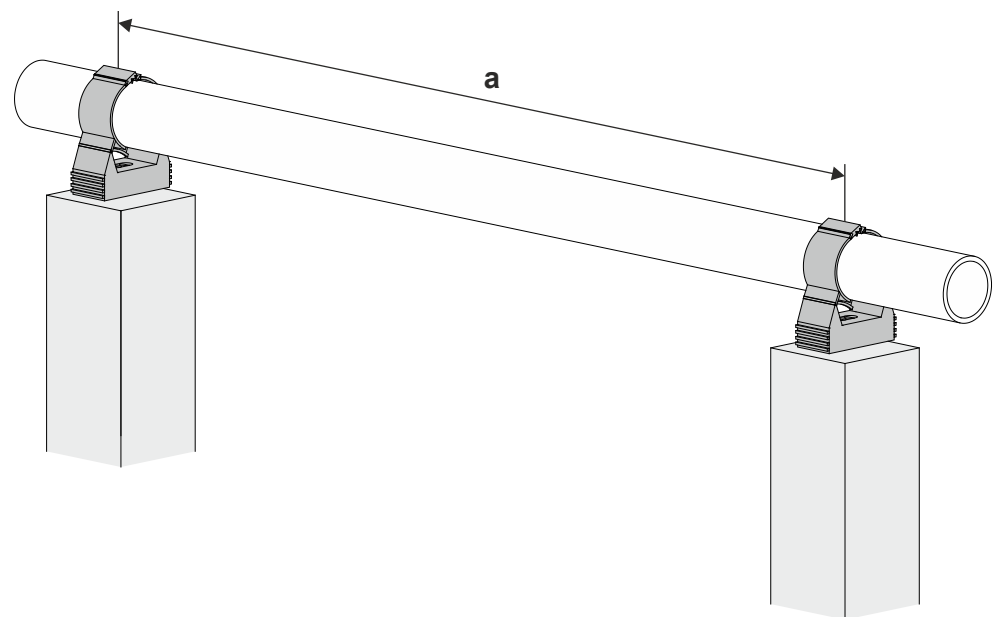

Securing pipes to supports

4.15 Installing upright stand pipes

In many cavities or ducts, lines or cables prevent the air from flowing freely to the aspirating holes in the pipes. In such cases, there must not be any aspirating holes in the pipes. Upright stand pipes can be used to take in the air without any obstructions.

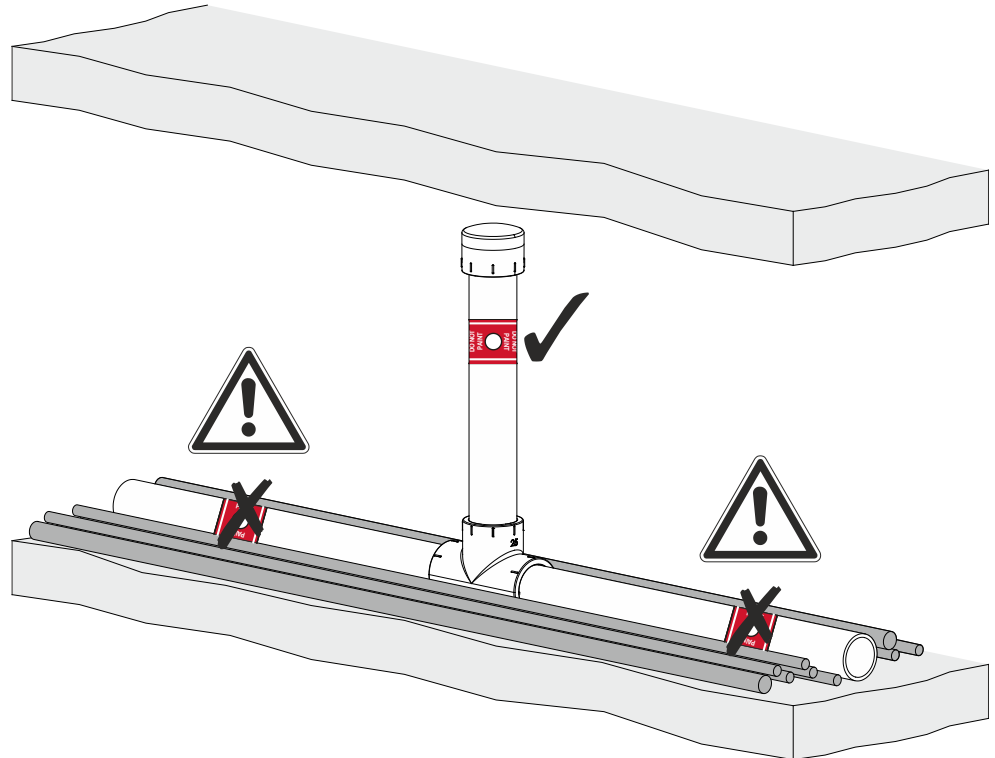

4.16 Sampling Holes

Aspirating holes in pipes

Aspirating holes typically have a diameter of 3 mm when the pipe is more than 20 m long. In the case of shorter pipes, the aspirating holes are generally larger than this. To achieve a balanced intake of air throughout the entire pipe system, use the 'FXS2055 ASD Asyst Tool' software to calculate the exact diameter required for the aspirating holes.

Aspirating holes in end caps

The end caps of the pipes also have aspirating holes in them. The size of the aspirating holes is used to align the airflows of the individual pipes with one another.

Exception: The end caps on the upright stand pipes do not have any holes in them.

4.17 Ambient conditions

Ambient conditions may affect the aspiration behavior of the pipe system.

Check the following factors:

- High air speeds
- Frequent air change
- Air pressure fluctuations
- Changes in air temperature
- Radiant heat
- High air humidity
- Vibrations

In light of the ambient conditions, it may be necessary to use an alternative material for the pipe system.

4.18 Conditions inside the room

The conditions inside the monitored room affect the design of the pipe system and the position of the aspirating holes.

Take account of the following:

- Does the room feature natural ventilation or mechanical ventilation?
- Are the conditions in the room constant or do they change?
- Is the room subject to smoke, dust, vapor, flames, vibrations, or heat?

4.19 High and open halls and rooms

High and open rooms include, for example, atriums, auditoriums, airplane hangars, exhibition halls, and warehouses. Inside rooms such as these, air layers may form. These air layers act as a barrier to free air exchange and may prevent the smoke from reaching the ceiling. In such cases, pipes with aspirating holes can be moved further down frames or walls.

4.20 Cavities in ceilings and floors

In the case of certain applications, cavities in ceilings and floors are suitable for extracting air. These cavities can be integrated into the pipe system so that they can be monitored reliably. This offers advantages in respect of cable channels in computer rooms, for example.

5 Mounting/Installation



The pipe system should be completely planned before mounting and installing the aspirating smoke detector and the electrical systems and equipment.



All piping must be installed according to local and national specifications and guidelines.

The 'FXS2055 ASD Asyst Tool' software provides the following data of relevance to installing the pipe system:

- Position of the aspirating holes in the pipe system
- Diameter of the aspirating holes
- Diameter of the aspirating hole in every end cap

5.1 Mounting principles

The air pressure at the aspirating smoke detector should be equal to or lower than the air pressure in the room containing the aspiration system. Otherwise, pressure equalization may occur as a result of the air being recirculated. You will find details of the maximum monitored area in chapter 'Limits to planning [→ 38]'.

- The choice of topology affects the size of the monitored area. It is essential to adhere to the authorized topologies and permissible dimensions. You will find precise details in chapter 'Limits to planning [→ 38]'.
 - Branches and bends reduce the performance of the pipe system.
 - Where systems involve multiple pipe branches, these branches should be the same length if possible. This ensures a balanced airflow.
 - Identical piping lengths and the number of aspirating holes are the key to adjusting the airflow.
- The size of the aspirating holes in the end caps can be used to control and balance the airflow in the pipes.
- Use the 'FXS2055 ASD Asyst Tool' software to calculate how to adjust the airflow and what size the aspirating holes should be.
- To prevent the pipes from sagging, they should be firmly secured at least once every 2 m.
- Use plastic pipes made from PVC or ABS with an inner diameter of 16...21 mm (outer diameter 25 mm).
 - An inner diameter of 16 mm is appropriate up to a pipe length of 20 m.
 - An inner diameter of 20...21 mm is appropriate up to a pipe length of 60 m.
- Use metal pipes if:
 - Mechanical forces act on the pipe system
 - Their use is stipulated by local regulations
 - Heat, cold, or solvents would result in damage to a plastic pipe system
- All pipe connections must be airtight.
- The connection to the aspirating smoke detector must be detachable for maintenance reasons and must not be glued.
- If the climatic conditions in the monitored room change compared with what was originally planned, the efficiency and reliability of the fire detection system plus aspirating smoke detector will deteriorate. Such changes include:
 - Different air pressure conditions in the room
 - The installation of an air conditioning unit or ventilation system
 - A change in the dust concentration

5.2 Installing the pipe system

- ▷ The pipe system must be designed in accordance with the requirements described in this document.
 - 1. Cut the piping with a pipe cutter. [→ 47]
 - 2. Remove the protective caps from the pipes.
 - 3. Deburr the projecting edges.
 - 4. The inside of the pipe must be clean and clear. Clean the pipe to remove dirt and grease.
 - 5. Only stick pipes and components together that have had dirt and grease removed from them. [→ 48]
 - 6. Only connect parts that fit together exactly.
 - 7. Pipes must not sag. Apart from in the case of expansion, they must not move. [→ 40] Therefore, use an adequate number of mounting components to install the pipes.
 - 8. The pipes must be able to expand unimpeded. Therefore, do not use rubber pads when installing the pipes.
 - The maximum distance between two retainers is 200 cm.
 - In locations that are subject to vibrations and severe fluctuations in temperature, the maximum distance between two retaining points is 30 cm.
 - 9. Connect the pipe system to the aspirating smoke detector.
 - 10. All the ends of the lines must be closed. Close all the ends with end caps.
- ⇒ The pipe system is installed.



Following installation, carry out a final inspection.

Final inspection

- Check that the pipe system is complete.
 - Have all components been fully installed?
 - Have all components been correctly installed at the specified location?
- Are there any cracks or signs of damage in the pipe system?
- Are any seals damaged?
- Are the positions of the aspirating holes correct?

5.2.1 Trimming the pipes

!	<p>NOTICE</p> <p>Swarf and dust in the pipe system Influence on the detection features of the aspirating smoke detector</p> <ul style="list-style-type: none"> • Only use a pipe cutter to trim the pipes. • Do not use saws or other cutting tools. • Purge the pipes of swarf or impurities by blowing them out.
----------	---

- ▷ Planning of the pipe system is complete.
 - ▷ The length of the pipes is defined.
 - ▷ A pipe cutter is available to trim the pipes.
1. Trim the pipes to the desired length using the pipe cutter.
 - Make the cut at a right angle to the pipe's longitudinal axis.
 2. If necessary: Deburr the interface with a file and remove the swarf produced.
- ⇒ The pipes are ready for installation.

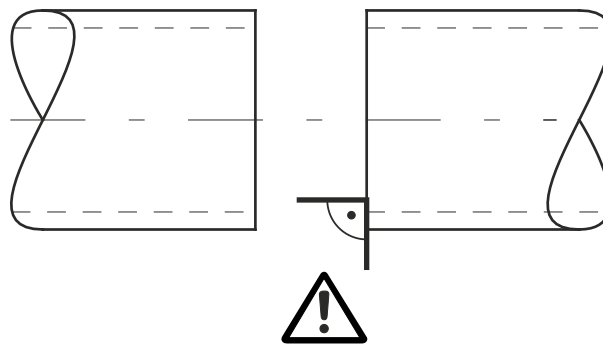

Right-angled cut when trimming pipes

See also

📄 Tools [→ 26]

5.2.2 Connecting pipes and fittings



⚠ WARNING

Easily inflammable solvents in the adhesive

Risk of fire upon contact with naked flames or hot surfaces

- Smoking, fire and naked flames are prohibited when working with adhesive!
- Ensure the room in which the adhesive is being used is well ventilated.



Use a clean brush to apply the adhesive. Do not apply different adhesives with the same brush.

- ▷ The pipes are trimmed to the desired length.
 - ▷ The required fittings, e.g. pipe connections, T-pieces and bends, are available.
 - ▷ Suitable adhesive is available for gluing pipes and fittings.
 - ▷ Pipes and fittings are connected in a dry room.
1. Press the pipe to the fitting as far as the stop.
 2. Draw a line on the pipe along the flange of the fitting to mark the pressed-in part of the pipe.
 3. Pull the pipe out of the fitting.
 4. **WARNING! Health risk when handling adhesive. Observe the instructions for use and the safety data sheet for the adhesive!**
 5. Apply the adhesive to the marked area on the end of the pipe. The marked area must be completely and evenly covered with adhesive.
 6. Slide the pipe into the fitting.
 7. Press the pipe and fitting together for at least 30 s.
 8. Remove the residual adhesive from the pipe with a cloth.
 9. Repeat the steps described for every fitting.
 10. Wait until the adhesive has dried.
- ⇒ The connected pipes and fittings can be installed on the wall or ceiling.

See also

 Adhesive [→ 26]

5.2.3 Installing end caps

Glue an end cap on to each open end of the pipe system as described in chapter 'Connecting pipes and fittings [→ 48]'.



An aspirating hole must be created in each end cap. The aspirating holes in the end caps usually have a larger diameter than the aspirating holes in the pipes. As a result of the end cap, an initial airflow is generated in the pipe system. Exception: The end caps on the upright stand pipes do not have any aspirating holes in them.

See also

- End caps [→ 25]
- Drilling the aspirating holes [→ 50]

5.2.4 Fastening the pipe system

The pipe system can be secured in various ways. Please refer to the following chapters:

Fastening on the ceiling

See chapter: Installing pipes on the ceiling (standard) [→ 41]

Fastening under the floor

See chapter: Installing pipes in false floors or channels [→ 42]

Installing upright stand pipes

See chapter: Installing upright stand pipes [→ 43]

Installing capillary tubes

See chapter: Air aspiration via capillary tubes [→ 18]

The basics of fastening

We recommend using fastening clamps, which can be installed on the wall or ceiling. The pipes are hung in the fastening clamps.

Observe the following points when fastening the pipe system:

- The exact installation procedure depends on the fastening clamps used and the available substructure. Use suitable dowels and screws.
- Pipes may expand due to fluctuations in temperature. Ensure that there is sufficient space for the pipes, e.g. to the side of the pipes.
- Ensure that there are no fastening clamps near the aspirating holes.
- Do not install any fastening clamps within an area of approx. 1000 mm in front of the aspirating smoke detector. This simplifies the process of removing the pipe system from the aspirating smoke detector for maintenance and cleaning.

See also

- Fastenings [→ 26]

5.2.5 Drilling the aspirating holes

The diameter and position of the aspirating holes in the pipe system and in the end caps are defined during planning.

The aspirating holes are drilled once the pipe system has been installed.

Information about drilling the aspirating holes

You must observe the following when drilling the aspirating holes:

- Only drill the planned diameter in the pipe system. Deviations from the planned diameter influence the effectiveness of the aspirating smoke detector.
- The planned diameter may deviate from one pipe to another. You should therefore check the required diameter before drilling and use the appropriate drill.
- Always drill the aspirating holes at a right angle to the pipes. If you do not drill at a right angle, the aspirating hole will not be circular and will therefore deviate from the planned diameter or impair the flow of air in the pipe system.
- Drill the aspirating holes from the bottom upwards.
- Do not drill through both walls of the pipe! Only drill in one wall of the pipe.
- Drill at a slow speed and with a sharp drill. This prevents dust or swarf entering the pipe system and impairing the effectiveness of the aspirating smoke detector.
- Deburr the drilled holes if necessary. The drilled holes must not be countersunk!

Labels can be stuck to the aspirating holes to identify them. The opening in the labels must be placed around the aspirating hole.

Work steps

- ▷ The pipe system is installed.
 - ▷ Information about the position and diameter of the aspirating holes is available.
 - ▷ Information about the diameter of the holes in the end caps is available.
1. Drill the aspirating holes at a right angle to the pipes.
 - Ensure that the aspirating holes in the pipe always face down.
 2. Drill an aspirating hole in every end cap.
 3. Purge the pipe system of possible swarf by blowing it out.
- ⇒ The pipe system is ready for connection to the aspirating smoke detector.



If the pipe system design dictates that an aspirating hole ought to be drilled in a fitting, proceed as follows:

Do not drill into the fitting under any circumstances! The resulting turbulence could impair the measurement result of the aspirating smoke detector.

Instead, offset the drilled hole in relation the fitting by moving it further along the flow in the direction of the aspirating smoke detector, as illustrated in the graphic below. Offsetting the drilled hole by up to 100 mm has no impact on the results detected by the aspirating smoke detector.

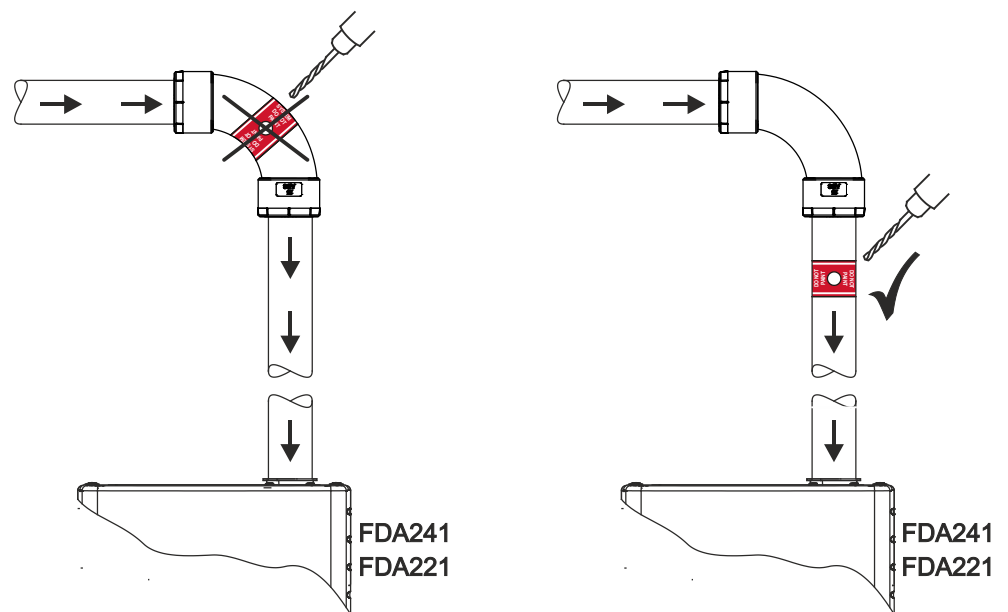

Arrangement of drilled holes away from fittings

See also

- 📄 Label for aspirating holes [→ 25]
- 📄 End caps [→ 25]

5.2.6 Connecting the pipe system to the aspirating smoke detector

!	NOTICE
	Connection between pipe system and aspirating smoke detector Damage to the pipe system and/or the aspirating smoke detector <ul style="list-style-type: none">• Do not glue the pipe system to the aspirating smoke detector! If the pipe system has to be separated from the aspirating smoke detector for maintenance work or repairs, components may be damaged.

- ▷ The pipe system is installed.
- ▷ The last 500 mm of the pipe system on the aspirating smoke detector must be straight, such that flow turbulences can be eliminated before entering the aspirating smoke detector.
 1. Press a short pipe securely into the air inlet on the aspirating smoke detector.
 2. Connect the pipe system and the pressed-in pipe piece to the aspirating smoke detector.
- ⇒ The pipe system is connected to the aspirating smoke detector.

You will find more information in document A6V10334410. See the chapter 'Applicable documents [-> 7]'.



Index

A

Air aspiration

- Direct, 16
- In capillary tubes, 18
- Into the pipe system, 16

ASD Asyst Tool, 13

C

Capillary tubes, 18

- Inner diameter, 18
- Maximum length, 18

Collective effect, 39

Components

- Features, 24

D

Drilling

- End caps, 50
- Sampling Holes, 50

E

End caps

- Drilling, 50

Equipment protection, 22

Examples of application, 13

F

Fastening clamps, 49

Fire compartments, 13

Floorplan, 13

L

Labels

- Sampling Holes, 50

O

Obs, 39

Original language

- Source language, 5

P

Pipe system, 13

- Connecting to the aspirating smoke detector, 52

Planning

- Prerequisites, 13

Pressure differences, 14

R

Room protection, 20

S

Sampling Holes

- Drilling, 50
- Labels, 50

Sensitivity

- Collective effect, 39
- Limit values, 38

Source language, 5

T

Topology

- Pipe system, 14

Issued by
Siemens Switzerland Ltd
Building Technologies Division
International Headquarters
Gubelstrasse 22
CH-6301 Zug
Tel. +41 41-724 24 24
www.siemens.com/buildingtechnologies

© Siemens Switzerland Ltd, 2011
Technical specifications and availability subject to change without notice.